

INTEGRITY PRODUCTS

Flange Belt

Always wear appropriate PPE (personal protective equipment) which conforms to applicable work safe standards.

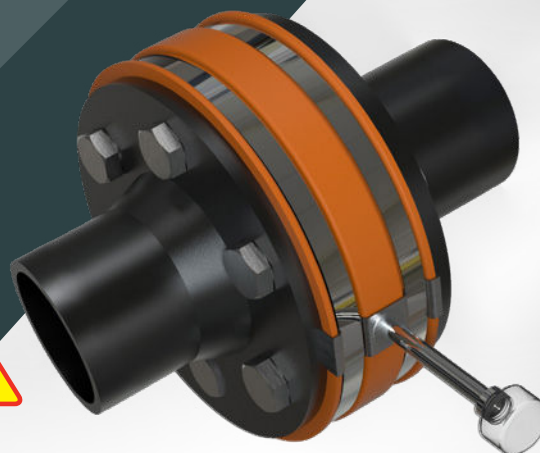

TOOLS REQUIRED



TIN SNIPS



SEALANT



1/2" BANDING

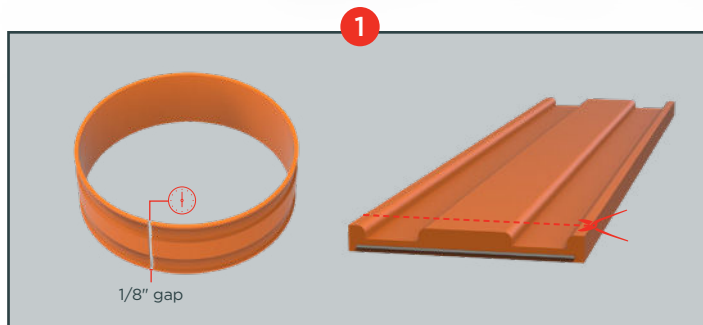

STEP 1

Ensure the surface of the flange faces are dry, clean, and free from debris.

Measure and cut the Flange belt to the circumference of the Flange leaving a 1/8" gap allowance at the 6 o'clock position.

Cut using sheers or tin snips to ensure a smooth & straight cut through the stainless steel insert.

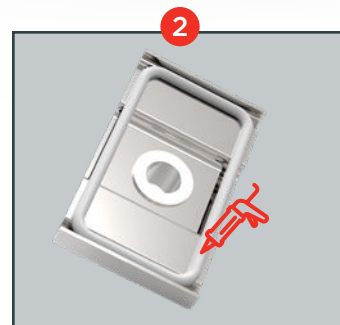

STEP 2

Apply a bead of sealant to the underside of the outer edge of the joiner.

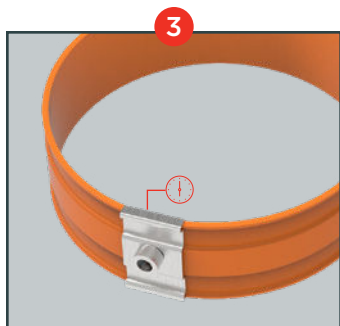

STEP 3

Align the joiner to the center of the 1/8" gap at the 6 o'clock position.



STEP 4

Place Stainless Steel banding into both grooves on the outer edges of the Flange Belt. To secure the joiner tighten the SS banding into place.

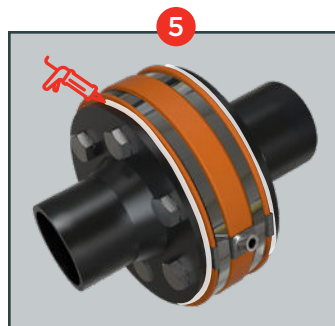

STEP 5

Apply a bead of sealant around the entire circumference of both sides of the outer edges of the Flange belt.

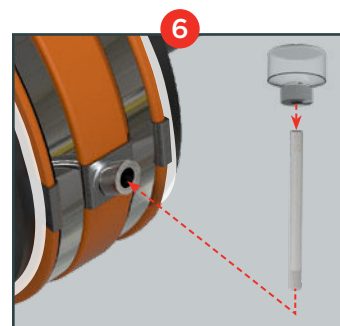

STEP 6

OPTIONAL STEPS FOR COLLECTION BOTTLE: Screw-in the threaded Stainless Steel tube into the joiner at the 6 o'clock position and attach collection bottle if required.